

The Ohio Valley Region's News

THE AAAAAA000GAH!

Published by the Ohio Valley Region of MARC-MAFCA



P.O. Box 62303 Sharonville, OH 45241

<http://clubs.hemmings.com/OVR/>

February, 2017

Aerial View

By: Director Conrad Gerdes



Hoping everyone had a great Christmas and a Happy New Year. I wanted to thank everyone who made it to the Christmas Party. If you're thinking of an outing or meeting for this year, let us know as soon as possible, as we're filling up the schedule.

Now is the time to get your car ready for reliable touring. We are looking for new members or old members to come back and if you are involved you'll receive extra tickets toward the Grand Participation Award at this year's Christmas Party.

We had a good turn out at the January meeting even though many of our members are on vacation. Hope to see you in February and don't forget your Valentine.

It's almost time to get your car on the road. Here are some troubleshooting tips if your car is stalling when coming to a stop.

Stalls When Stopping Taken from: <http://www.modelabasics.com/carb%20basics%202.htm>

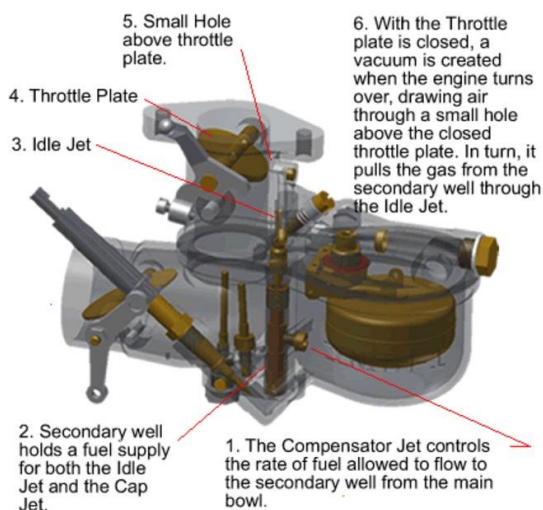

5. Small Hole above throttle plate.

4. Throttle Plate

3. Idle Jet

2. Secondary well holds a fuel supply for both the Idle Jet and the Cap Jet.

1. The Compensator Jet controls the rate of fuel allowed to flow to the secondary well from the main bowl.

6. With the Throttle plate is closed, a vacuum is created when the engine turns over, drawing air through a small hole above the closed throttle plate. In turn, it pulls the gas from the secondary well through the Idle Jet.

7. Theory: The float setting is causing the fuel to be too low in the main bowl. When the vehicle stops, all of the fuel in the main bowl moves forward, starving the secondary well. The Idle jet uses up the fuel in the secondary well and the engine starts to stall. The driver compensates by revving the engine which engages the Cap Jet. When the vehicle comes to a complete stop, the engine slowly comes back to idle, as the Secondary Well Begins to fill.

Other idea's: Cap Jet not allowing enough fuel in. One of the passages leading to the small hole above throttle plate is partially blocked with rust or debris.

Director

Conrad Gerdes
13591 US 50
Dillsboro, IN 47018
(812) 432-3631
dottieg0@centurylink.net

Vice Director

Steve Gillie
6780 Bunnell Hill Rd.
Springboro, OH 45066
(513) 571-5276
stevenagillie@msn.com

Secretary

Phyllis Pease
4456 Schinkal Rd.
Cincinnati, OH 45248
(513) 941-1020
phyllis.pease@gmail.com

Treasurer

Bob Green
9735 Baughman Rd.
Harrison, OH 45030
(513) 717-4195
modelabob@hotmail.com

Membership Director

Jarrold Williams
7973 Miami Ave
Cincinnati, OH 45242
(859) 802-7267
jarroldwilliams81@gmail.com

Sunshine Lady

Margie Blomer
11565 Wyscarver Rd
Cincinnati, OH 45241
(513) 769-3029

For Technical Topics

Contact:

Lee White
(513) 941-1020

For news and special events

Contact:

Margie Blomer
(513) 769-3029

Annual Membership is \$25.00

Contact:

Jarrold Williams
(859) 802-7267

The Model "A" Restorers Club
 is proud to introduce

 of the
**RESTORATION GUIDELINES
 AND JUDGING STANDARDS**

Whether you're restoring a Model "A" or in search of the definitive book of standards for Model "A" Fords, this is the volume you need! Packed with all the information, part numbers, and correct applications for Model "A" Fords (including sections on AA, AR, and Canadian vehicles), this book covers the areas you need to make your Model "A" as authentic as Henry made it.

Simply contact the MARC office for your copy of these long awaited reference volumes as they're ready for immediate shipment to your door.

 **Call 734.427.9050 NOW!**
Office Hours: Monday - Friday 8 AM-4 PM EST

Coming Together in Shipshewana



2017 MARC Membership Meet
March 23, 2017 – March 26, 2017

Services

- ◆ G&G Classic
 (812) 584-5639
 - Partial and complete restorations
 - Engine changes
 - Glass replaced
 - parts and service
 - wheels painted
 - steering rebuilt
- ◆ Dottie's Upholstery Shop
 (812) 584-5631
 - New tops for sedans and convertibles
 - Custom Upholstery or kits. 5% discount for MARC members
 - Made-to-order trunks (you choose color)
 - Some upholstery repair

Show your support of the Ohio Valley Region Model A Club!

We are pleased to announce that we no longer have to wait for multiple people to place an order for club apparel. OVR club shirts, jackets, etc. can be purchased at Black Out Tee's in Eastgate Mall. The company has our logo in digital format and can help you place your order. Club name tags (in the shape of a Model A) can be ordered at a cost of \$10.00 (tag with pin) or \$12.50 (tag with magnet).

Black Out Tee's
Eastgate Mall
4601 Eastgate Boulevard
Cincinnati, OH 45245



Horn Rod *Light Switch* Replacement

By: Scott Conners, Stephentown, New York.

After discovering when I turned the steering wheel on my 1930 Ford Model A Pickup that my light switch was turning and giving me flashing lights as I went down the road, I decided to tackle the horn rod and light switch replacement.

After receiving the replacement parts, I found that several of them were not the best quality after putting this all back together several times and feeling frustrated and puzzled as to why things weren't working. So in an attempt to help others, I decided to document my repair in this article.

Since my vehicle was a truck, I had to take the steering column out through the driver's side door. This is easier done with two people, but I did it myself in the garage, so one person can do this.

PART I:

Before we get into the actual removal and installation of the horn rod and light switch we have to remove the steering column. To do that you need to do the following:

1. Remove the floor boards
2. Disconnect the battery
3. Remove the starter
4. Remove the throttle and spark control linkage rods
5. Release the bail wire switch and pull the light switch bulb from the end of the steering column
6. Next, remove the light switch spider from the horn rod tip. To do this, you must remove the retaining clip from the bottom. I found that using a light switch spider install tool (available from most Model A parts suppliers) made this task much easier.



Spider Install Tool



7. From under the left front fender, remove the cotter pin and castle nut from the pitman arm and remove the arm. Then remove the two sector housing to frame castle nuts and bolts.
8. From inside the vehicle, remove the two screws holding the steering column bracket and rubber bushing, thus freeing your steering column.
9. Your steering wheel should now be able to be maneuvered out of the driver's door. You do not have to remove it totally from the vehicle. You should be able to slide the horn rod out of the column.



Remove throttle and spark control linkage



Remove cotter pin and castle nut from the pitman arm and remove it and then the two sector housing to frame castle nuts and bolts

PART II:

Now that you've got the steering column removed and the horn rod and light switch out of the column, you'll notice a small brass bushing called a light rod bushing in the center of the steering column. If you don't have one of these, you will need to order one.

1. The first thing I did was to sand down the entire horn rod to make it easier to fit inside the column. I did this by slicing a small piece of rubber hose lengthwise and inserting the sandpaper inside so I could slide it onto the horn rod and sand evenly.
2. Clean the hole in the steering wheel with a round file, not much but enough to clean any debris out.



3. I used my original spider that was in the pickup instead of the new one I bought.
4. Spin the light switch handle to make sure the horn rod spins freely with no binding. Sometimes it is just a slight bend in the horn rod that causes it to catch inside the steering column. Sometimes the tabs on the bottom side of the horn button will catch on the steering wheel nut. To correct this, I add a thin brass washer at the top of the rod, just under the horn button assembly.
5. The new stop light switch housing would not stay up in the steering column. So I opted to use my old light switch housing top and new bottom. NOTE: I had to use a Dremel to file down the two tabs on the bottom of the new housing so it would fit and turn into the top of the old housing. Go slow here if you have to do this and keep checking the fit.
6. After everything was back in, I had to keep adjusting the bail wire to make sure it kept the light switch housing in the column tight. The key is to make sure the tab slides up into the column from the top part of the switch and STAYS in the column and doesn't slip out. This took several tries of trial and error and bending of the bail wire and putting it back on.
7. I now have parking lights, low beam, high beam, horn, and the light switch doesn't turn when I turn the wheel.

So in retrospect, there were several issues going on. The first was that some of the repro parts I bought were not high quality, which taught me the lesson to use original parts whenever possible. The second issue was that the horn rod DID need to be sanded the entire length and not just at the top and bottom. The third was that the bail wire needs to hold that switch firmly up in the column.

Ohio Valley Region Model A Club Meeting Minutes January 25, 2017 VFW Hall Sharonville, OH

CALL TO ORDER: The meeting was called to order at 7:40 p.m. by Conrad Gerdes, Director. The Pledge of Allegiance was led by Meredith Owens.

ROLL CALL: The roll call was led by Steve Gillie, Vice Director. There were 40 members, 1 guest and 1 youth present. Conrad Gerdes asked members to submit suggestions for programs to increase meeting attendance.

TREASURER'S REPORT: The treasurer's report was approved as printed in the January 2017 AAAOOOGAH.

SECRETARY'S REPORT: The minutes of the November 16, 2016 meeting were approved as printed in the January 2017 AAAOOOGAH.

SUNSHINE REPORT: Margie Blomer noted that long-time member, Mary Cradler, passed away last week. Services were held. Dottie Meyer has been hospitalized recently and is now resting in a rehab facility. The son of member Russ Andrews was recently killed in a motor vehicle accident. Anne Perry fainted at Mary Cradler's funeral and was briefly in the hospital. There were 6 January birthdays noted, no January anniversaries.

FASHION REPORT: Phyllis Pease reported that the MARC Fashion Committee will meet at the MARC Membership Meet in Shippshewana, IN in March. The seminar will be "1930 Fashions".

2017 ROSTERS: Jarrod Williams was extended a thank you for producing the 2017 club roster and having it available at this meeting. Rosters will continue to be available at club meetings. Each member is entitled to one free roster; additional copies are \$1.00.

MILEAGE REPORTS: Anna Williams needs the mileage of participating cars as of December 16, 2016. The report is due to the MARC Mileage Committee by February 1, 2017. Please call or email Anna ASAP.

50th ANNIVERSARY BADGES AND AROUND THE WORLD DVD'S: Bob Green still has a supply of 50th Anniversary commemorative radiator badges available for \$5.00 each. Jim Thomas has additional "Around the World in a Model A" DVD's available for \$5.00 each.

UPCOMING EVENTS: Phyllis Pease reported that Larry and Debbie Arnold will host a Polar Bear tour in early April. This will possibly be an overnight event. Details to follow. The Arnolds will also host the Poker Run in July, date to be announced. For May, Denny Perry will possibly reschedule the tour which was cancelled in November 2016 due to inclement weather.

UPCOMING SWAP MEETS: Conrad Gerdes has a flier for the March 4, 2017 swap meet in Marietta, OH. Call Conrad for details. The annual Columbus, IN swap meet will be held Sunday, April 30, 2017 from 7:00 a.m. to 2:00 p.m.

SUMMER PICNIC MEETINGS: It was decided to reinstate the June club meetings in addition to the annual Oeders Lake picnic. Lee White and Phyllis Pease will host this year on Wednesday, June 28, 2017. The Arnolds have volunteered to host the Wednesday, August 23 meeting but will be requested to move to the Wednesday, July 26, 2017 slot.

MARC/MAFCA FREE MEMBERSHIPS: Both MARC and MAFCA are offering free limited time memberships to first-time members. MARC is offering a 6 month membership; MAFCA is offering a full year membership. Contact Lee White if interested.

Model A Ford Foundation, Inc. DONATION: After some discussion it was agreed by vote to make a \$250 donation to MAFFI.

READING CAR SHOW: Elmer Stanukinos reported that O'Reilly Auto Parts will once again sponsor the trophies for the Reading Car Show. The tall trophies for the Top 50 cars will be replaced by an opaque style. Jeff Pulman will no longer be a Car Show sponsor, but will be replaced by Valley Central Bank. Members should begin selling \$50 sponsorships to be included in the sponsor booklet. Also members are encouraged to submit recipes to be printed in the book. There was a lengthy discussion about having a swap meet at the car show. A volunteer is needed to coordinate this effort. Contact Elmer if you are willing.

DONATION TO VFW: After some discussion it was voted to donate \$250 to the VFW general fund in lieu of monthly rent for the meeting hall.

SPLIT-THE-POT: \$55 was won by Mary Lou Cain.

ADJOURNMENT: The meeting was adjourned at 8:40 p.m. by Conrad Gerdes, Director

TECH SESSION: Immediately following the meeting Lee White conducted a tech session which included information on two new publications, "The Tudor Book" and a book on Ford Motor employee badges. In addition, distributor hints were given and also the use of the handy NU-Rex spark timing tool. There was discussion about collectable Ford Script cigar boxes and demonstration of a mirror to detect fuel levels during the fueling process.

NEXT MEETING: The next meeting will be held on Wednesday, February 22, 2017 at 7:30 p.m. at the VFW Hall, Sharonville, OH.

SUBMITTED BY: Phyllis Pease, Secretary

Upcoming Events

- ◆ **February 22 2017 - Sharonville, Ohio**
OVR Model A Club Meeting
VFW Post 4368. 3318 East Sharon Road, Sharonville, Ohio 45241
This is our usual spot for our monthly meetings. The VFW Hall has a dinner at 6:00 p.m., and we can get a home-cooked meal for around seven dollars if you are interested. The VFW lets us use their hall for no-charge. The only thing they ask is that we buy any drinks that we may want from them. Our meeting will start at 7:30 p.m. There is a rumor that the brand new 2017 OVR Rosters will be available for distribution.
- ◆ **March 4, 2017—Marietta, Ohio**
2017 Winter Swap Meet, Washington County Fairgrounds
The event is sponsored by the Country Roads T & A Ford Club and the Mid-Ohio Valley Ford and Mustang Club. The event will be held inside the Jr. Fair Building. Admission is \$5.00 per person and children under 12 are free. The doors will be open from 7:00 AM to 3:00 PM. Parking is free. For more information call (740)-538-0023 or email oldcarboy23@gmail.com
- ◆ **March 23-27, 2017—Shipshewana, IN**
2017 MARC Membership Meet
This year the MARC membership meeting will be held in Shipshewana Indiana. The area is celebrated as the third largest Amish community in the United States. There are many things to do in the area including:
 - The Hudson Automobile Museum
 - The Auburn, Cord, Duesenburg Museum
 - Ford V-8 museum
 - Studebaker Museum
 - Quilts Crafts and moreFor more information contact:
Andy Honiotes
(812)-954-1928
modeltandy@att.net
- ◆ **Early April**—Larry and Debbie Arnold will host a Polar Bear tour in early April. This will possibly be an overnight event. Details to follow.
- ◆ **April 30, 2017—Columbus, IN**
54th Annual Model A Ford Swap Meet
7AM-2PM. Admission \$3. Sponsored by Columbus Indiana Model A Club at: Bartholomew County 4-H Fairgrounds
State Road 11 and County Road 200 South
www.modelacolumbus.com
For more information contact: Larry Morlock
3407 Woodland Place Columbus, IN 47203 (812)-371-6628
- ◆ **May-** Denny Perry will possibly reschedule the tour which was cancelled in November 2016 due to inclement weather.
- ◆ **June 28—OVR Club Meeting** at Lee White and Phyllis Pease's home.
- ◆ **July**—Larry and Debbie Arnold will also host the Poker Run in July, date to be announced.
- ◆ **July 30—August 4, 2017—Gettysburg, PA**
2017 MARC National Meet
Hosted by the Hub City Model A Ford Club
<http://hubcitymodelaclub.com/marc-meet-2017>
Details to be announced when they are finalized.
- ◆ **September 10, 2017—8th Annual Show 'N' Tell Car show**
Details to follow

Classifieds

- ◆ 1930 Model A Tudor Completely Restored. Trunk Rack, Front Tool Box, overdrive, and new tires.
\$14,900 Call Conrad (812) 584-5639
- ◆ Model A trailer with Model A wheel
\$1,500 Call Conrad (812) 584-5639
- ◆ Model A single wheel trailer
\$300.00 Call Conrad (812) 584-5639
- ◆ New inserted rebuilt engine \$2,500.00. And two "good" used engines
Call Conrad (812) 584-5639
- ◆ 1930 Sports Coupe. Restored with Balanced B engine with overdrive.
\$25,000 Call Ermil Cain (513) 793-6951
- ◆ 1931 Slant Window. Restored . B-Engine. Everything is 1st class. 6 wheel with overdrive.
\$27,500 Call Ermil Cain (513) 793-6951
- Car trailer for Model A or T. Pulls great, pressure treated wood and the metal painted with POR-15.
\$1,000.
Steve Gillie
(513) 571-5276



Ohio Valley Region Model A Club Calendar

February 2017

Sun

Mon

Tue

Wed

Thu

Fri

Sat

			1	2	3	4
5	6	7	8	9	10	11
12	13	14 <i>Valentine's Day</i>	15	16	17	18
19	20 <i>President's Day</i>	21	22  Club Meeting	23	24	25
26	27	28				

The Passing of Mary Cradler

Prayer Requests



On Tuesday, the 17th of January 2017, Mary Cradler lost her battle with Cancer as she passed away in her sleep. The OVR Model A Club lost a lifetime member who followed her husband Larry, and son Dave, to a better place. Her services were on Saturday, the 21st of January. Please say a prayer for the Cradler

Family and keep Mary in your thoughts. She will be missed by many. Rest in Peace Kind Lady, we will miss you.

- ◆ Joe Shimi was in the ICU at Grandview Hospital with serious issues. The family is asking everyone to say a few prayers for Joe. We will keep you posted on any further developments.
- ◆ Steve Gillie's son, Adam Gillie, was recently in a motor vehicle accident, but has survivable injuries.
- ◆ Please say a prayer for Mary Cradler's family and friends.
- ◆ If you have prayer request you can call or email Jarrod Williams to have them included in next month's news letter.



Ohio Valley Region Model "A" Ford Club Membership Application and Roster Information

Last name: _____ First name: _____ Initial: _____
Spouse name: _____ Home Phone: ____/____/____
Address: _____ Apt./Suite: _____
City: _____ State: _____ Zip: _____
Cell (optional): ____/____/____ Work (optional): ____/____/____
Email : _____
Model A's Owned: _____

Make checks payable to : Ohio Valley Region Model A Ford Club (\$25.00 per year)
Mail dues to : Jarrod Williams 7973 Miami Ave Cincinnati, OH 45243



February 2017 Newsletter

Ohio Valley Region Model A Ford Club
P.O. Box 62303
Sharonville, OH 45241



Ohio Valley Region Model "A" Ford Club Membership Application and Roster Information

Last name: _____ First name: _____ Initial: _____
Spouse name: _____ Home Phone: ____/____/____
Address: _____ Apt./Suite: _____
City: _____ State: _____ Zip: _____
Cell (optional): ____/____/____ Work (optional): ____/____/____
Email : _____
Model A's Owned: _____

Make checks payable to : Ohio Valley Region Model A Ford Club (\$25.00 per year)
Mail dues to : Jarrod Williams 7973 Miami Ave Cincinnati, OH 45243